



DONGGUAN HACHENG MOULD CO., LTD

YOSHIKAWA KOUGYOU(H.K)CO.,LIMITED

Precision mold spare parts manufacturer

ISO9001-2015

ISO14001-2015



About YOSHIKAWA

Factory



Hacheng founded in 2014, occupied 1,200 square meters. Specializing in manufacture of connector mold parts, precision medical mold parts, precision metal stamping mold parts etc. There are 53 employees: 12 technicians with more than 15 years of experience, 21 technicians with more than 10 years of experience, 6 technicians with more than 5 years of experience, and 4 technicians with more than 2 years of experience.



About YOSHIKAWA

Company culture



1. **Honesty and trustworthiness, mutual respect**
2. **Teamwork and help each other**
3. **Focus on communication and create a good environment and promotion space for employees**
4. **High quality manufacturing and service**
5. **Lifelong Learning**



Our Service

- High quality material
- Good heat treatment process condition
- Reasonable processing technology
- Experienced staff
- Good machining accuracy
- Excellent surface roughness

1. High precision, high life

- Cross-departmental engineers
- Project briefing mechanism
- Group work mechanism
- Fixture, automation
- Engineering technical guidance

3. Process Optimization, cost advantage

2. Short delivery time, excellent quality

- Delivery from 1day
- Full size inspection
- 24H production system
- Quick response quotation
- 31 day production system

Connector mold parts
 Medical mold parts
 Precision metal stamping parts

- Assembly confirmation
- PDF=》 3D or 3D =》 2D
- Water leak test confirmation

5. +@

4. Good plan, Guaranteed delivery

- Flexible production planning
- All processes are seamlessly connected
- Information communication mechanism
- Good habits ensure yield



Department

■ Staff: 53

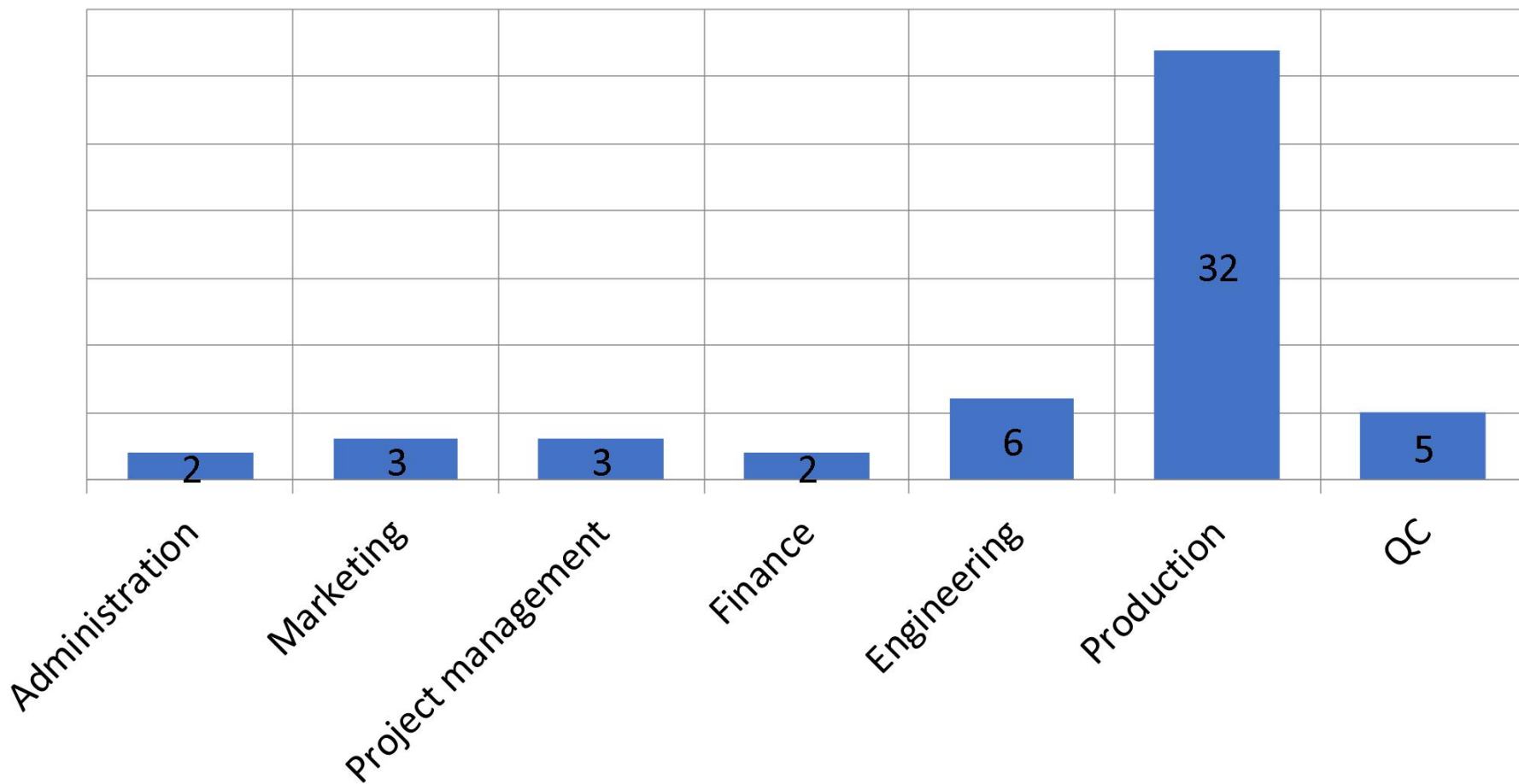



About YOSHIKAWA

Annual sales

Unit: million RMB

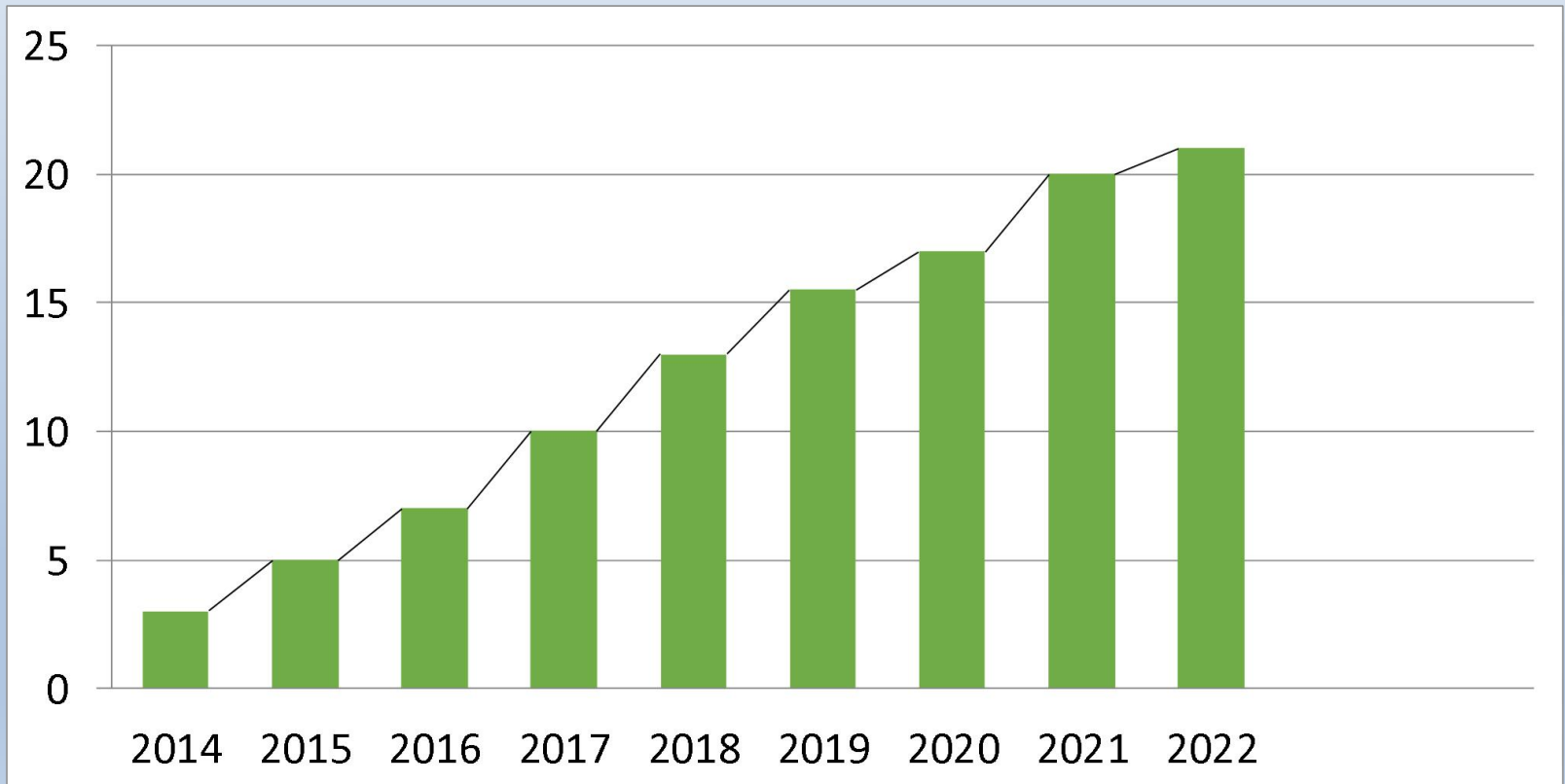



Service Area

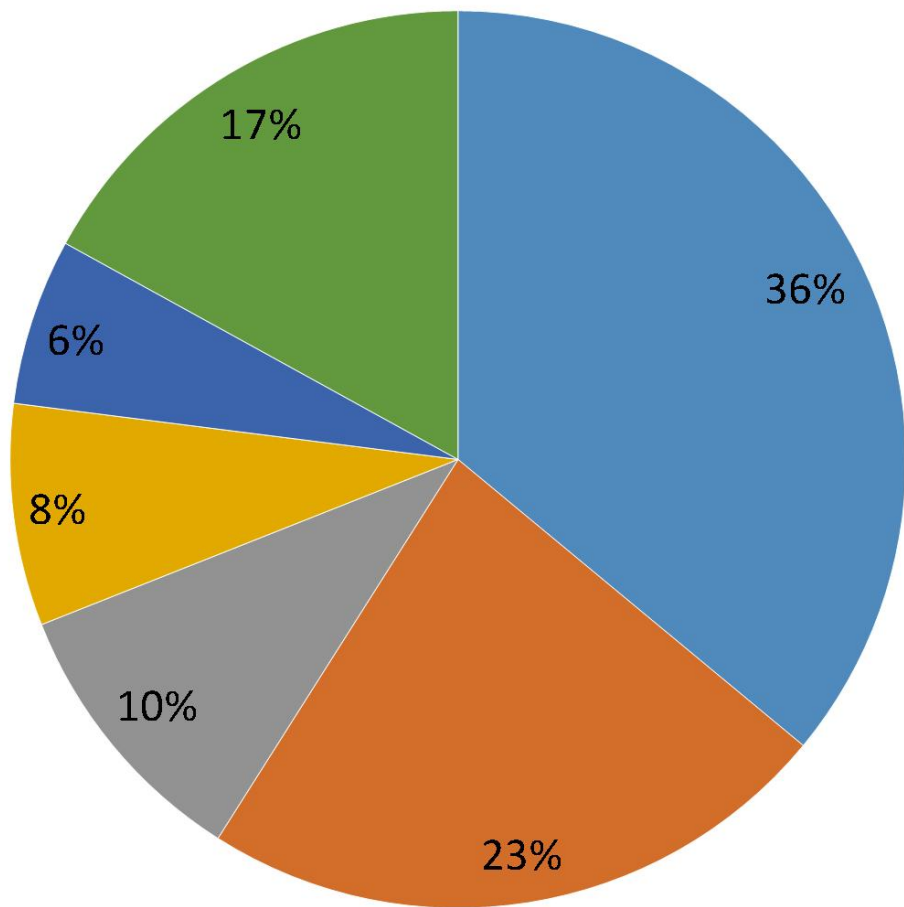

- Connector mold parts
- Medical mold parts
- Precision metal stamping die parts
- Automation parts
- Precision electronic mold parts
- Precision mold parts



About YOSHIKAWA

Marketing Share

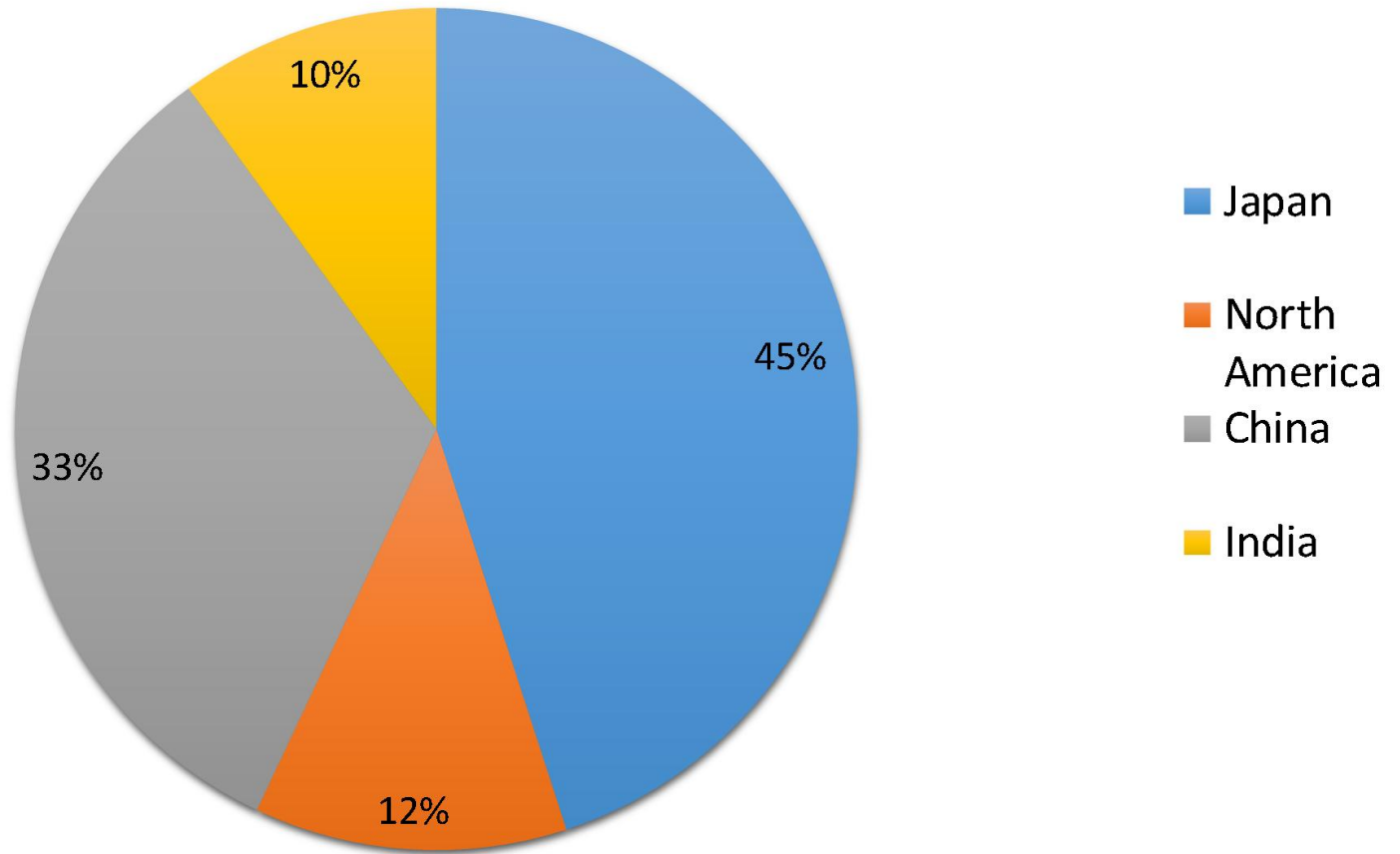



About YOSHIKAWA

Customer



Yazaki Componentes de Mexico, S. de R.L. de C.V. (YCC)



SMK Electronics (Dongguan) Co., Ltd.
東莞昭和电子有限公司

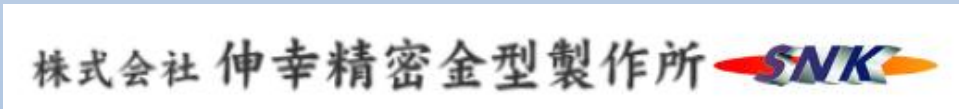

Yokowo 东莞友华汽车配件有限公司





About YOSHIKAWA

Our suppliers

Steel Supplies



SCHMÖLZ + BICKENBACH
Providing special steel solutions



Standard Components Supplies



Shipping company





About YOSHIKAWA

Organization Chart

General Manager

Assistant

Production

Engineering

Project & Purchasing

Administration and Financial

QC

Marketing

Grinding

Wire cutting

CNC

EDM

Process Optimization

programming

Production Planning

Purchasing

Administration and Financial

Quality Inspection

Quality Assurance

Marketing North America

Marketing Japan

Square parts

Round parts

Normal

Precision

Electrode

Steel

EDM

production process engineer

cost accounting engineer

Electrode Design Engineer

programming engineer

Production planning

Progress

Standard parts

Raw material

Personnel attendance

Financial Accounting

Logistics Services

measurement inspector

training engineer

Quality Engineer

English

Japanese

Cooperation Process

First Step

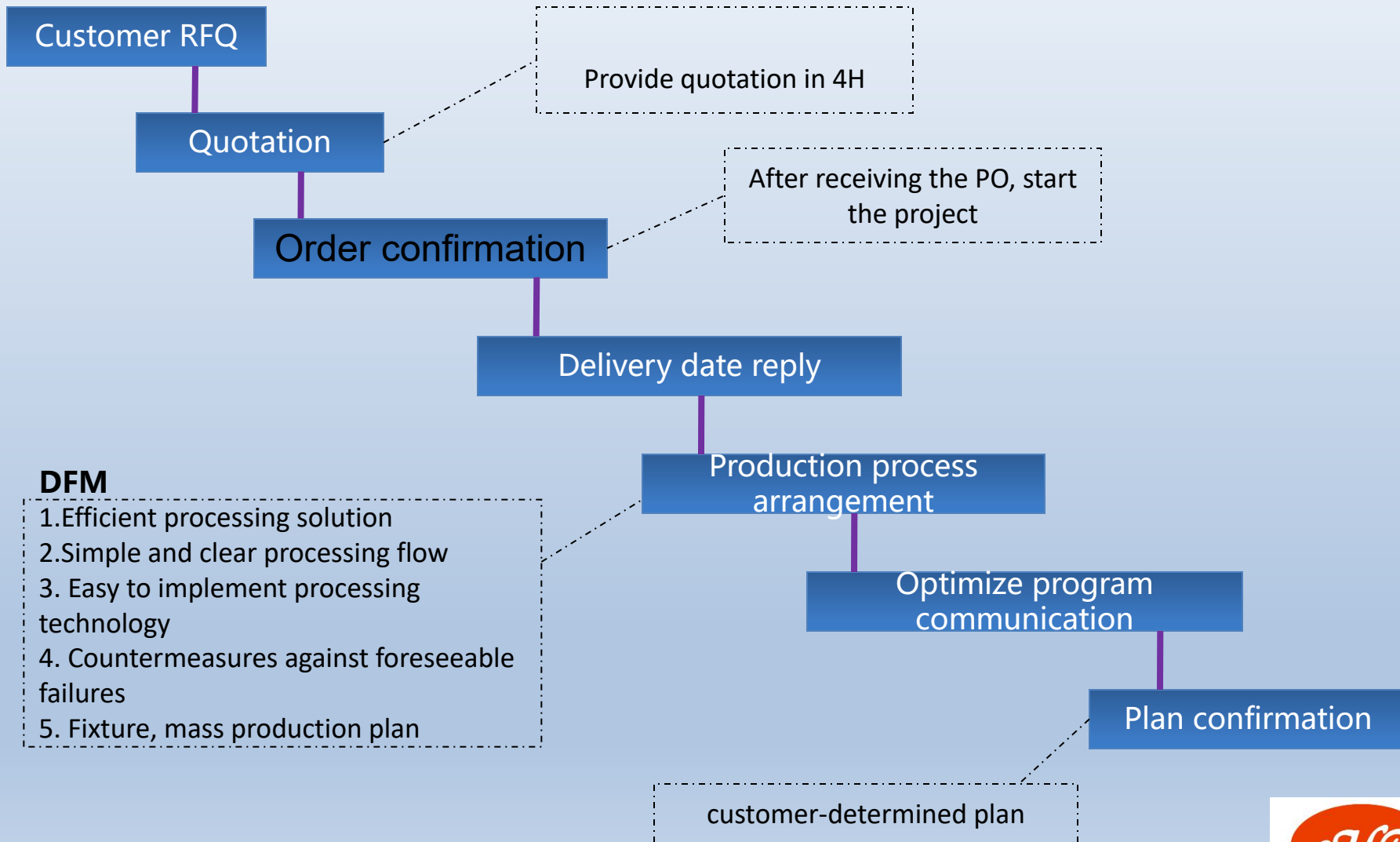

Cooperation Process

Second step

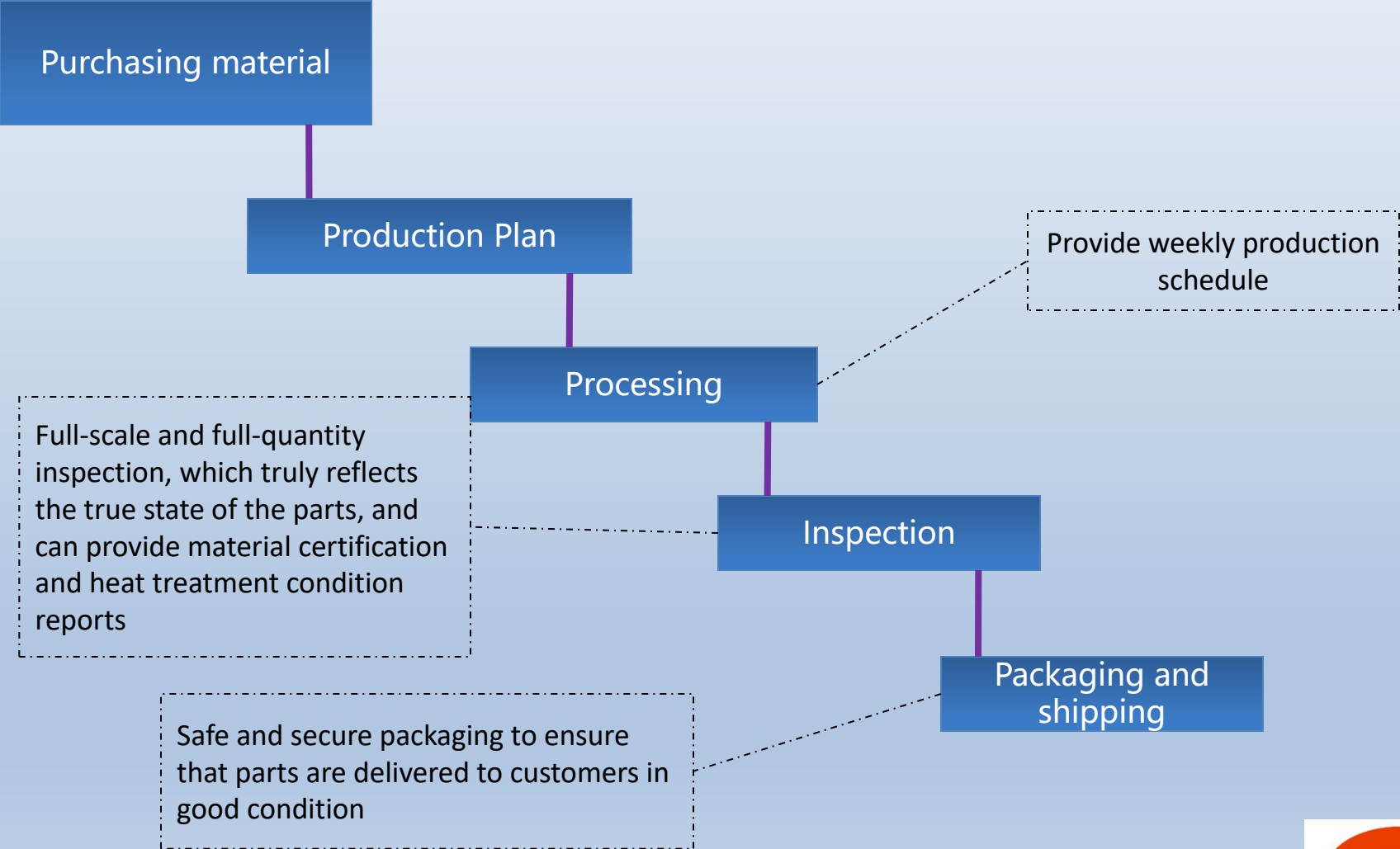



About YOSHIKAWA

Precision mold parts

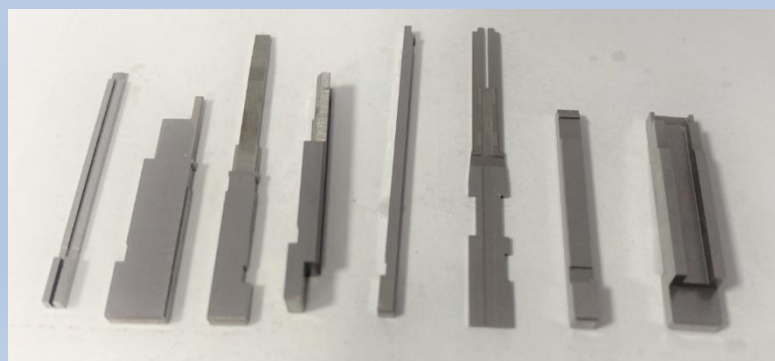
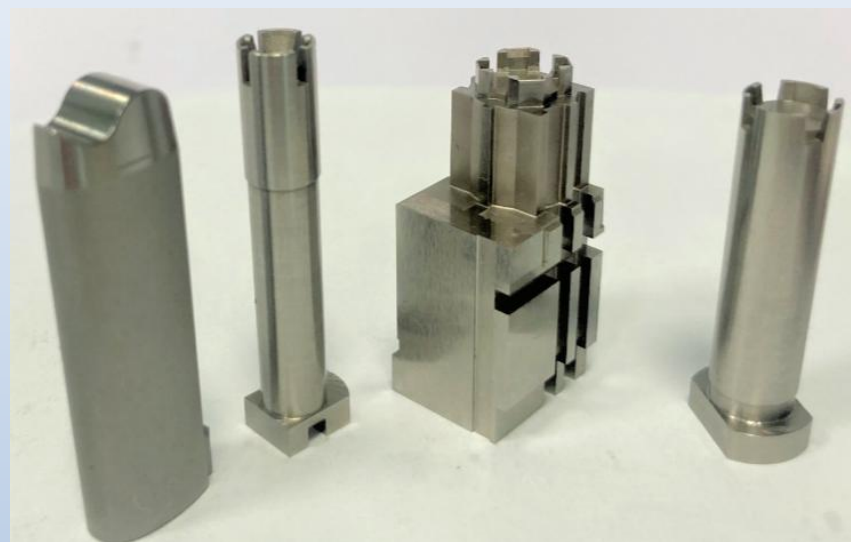
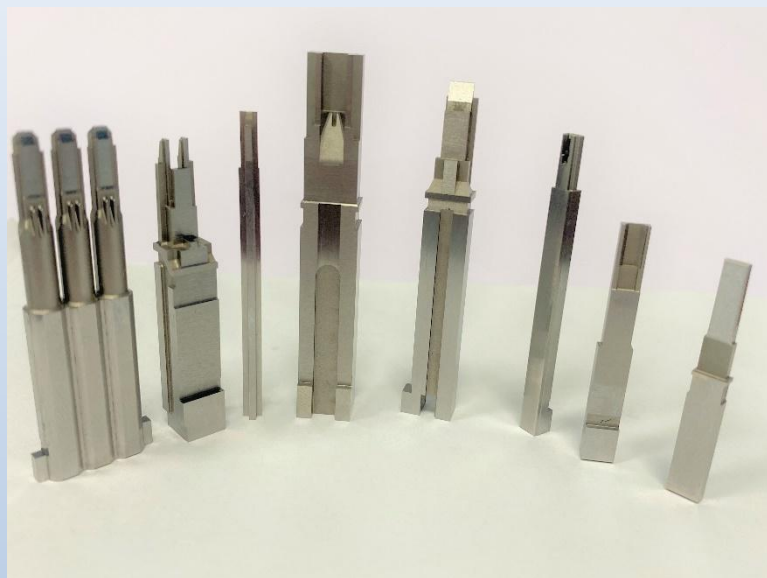



About YOSHIKAWA

Auto and Medical precision mold parts

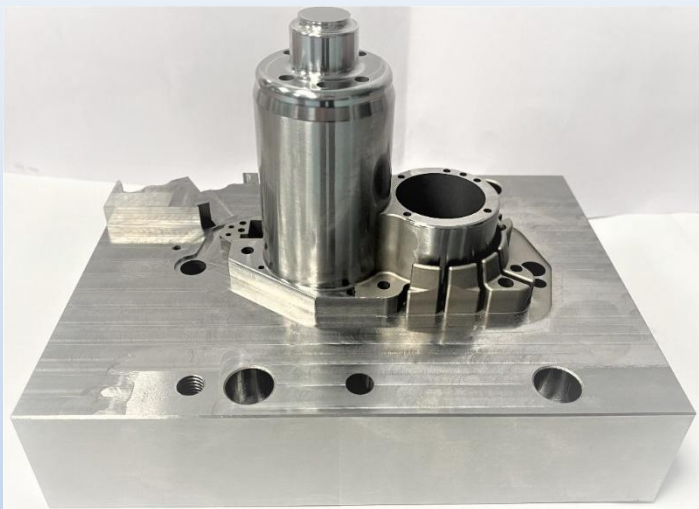

Material: HPM38
Size: 180*130*130
Time: 15 days



Material: STAVAX
Size: 190*120*40
Time: 10 days

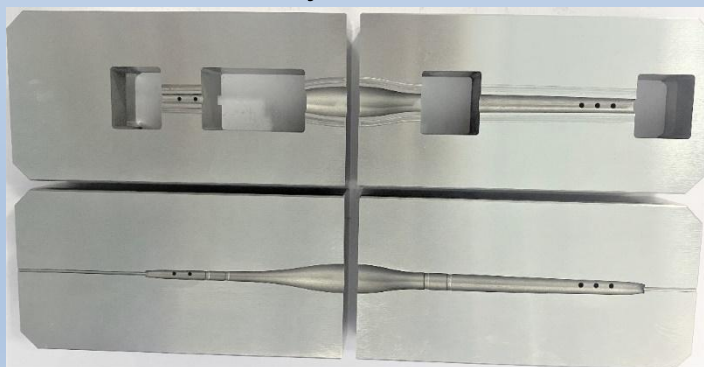

Material: SKD61
Time: 7 days

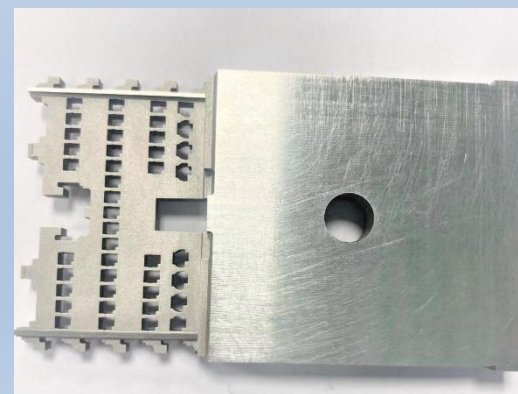

Material: RIGOR
Time: 10 days



About YOSHIKAWA

Auto Connector mold parts

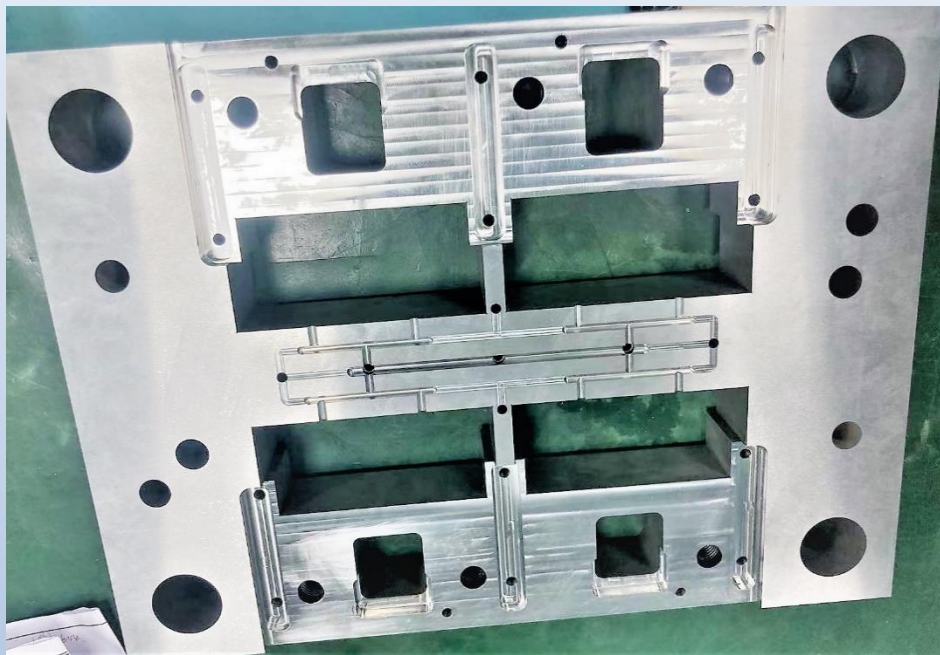

Material: PD555
Size: 400*300*55
Time: 20 days

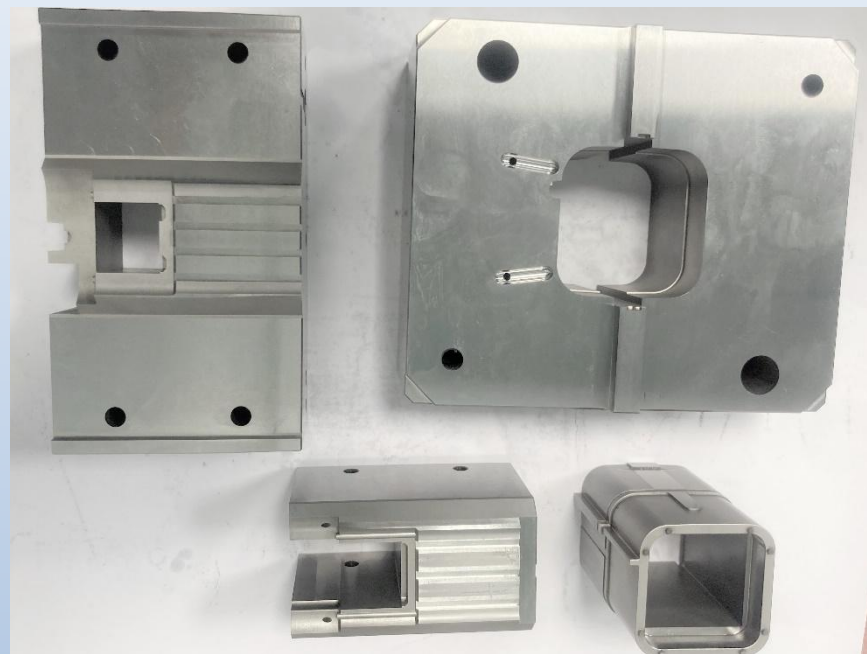

Waterproof connector mold
parts
Material: SKD11
Time: 10 days



About YOSHIKAWA

Automation parts and fixture parts

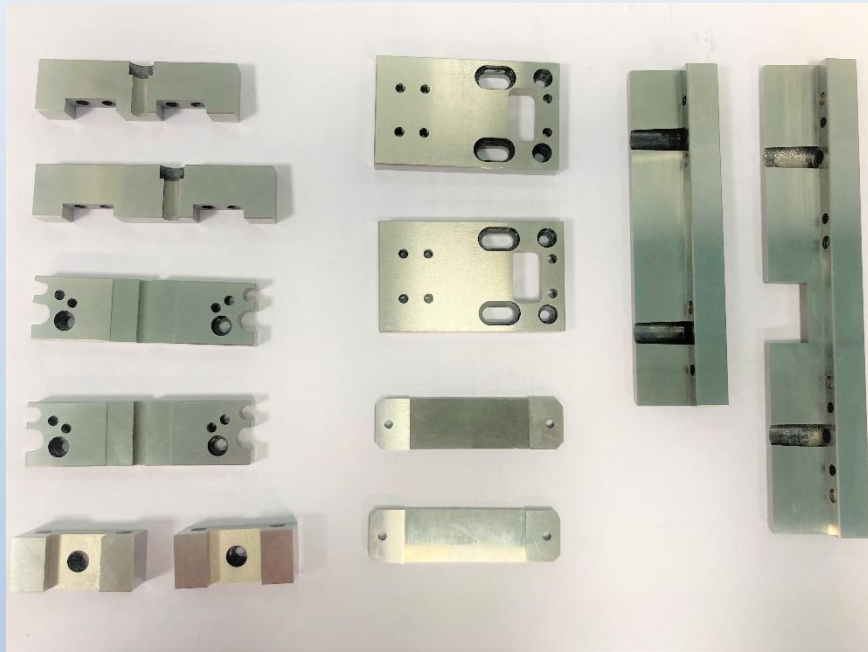

Steel precision parts

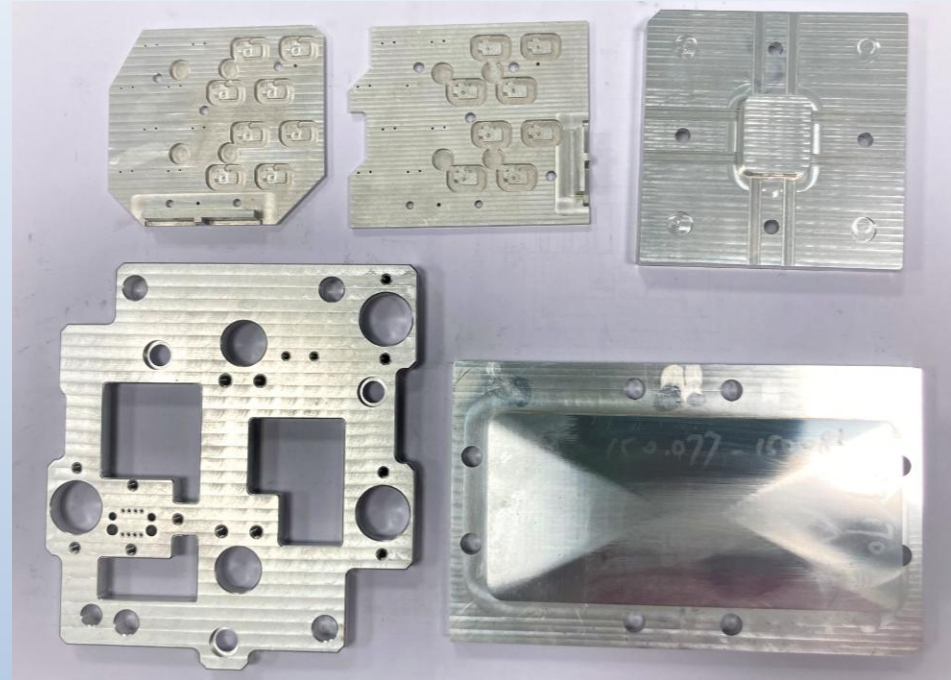

Aluminum precision parts

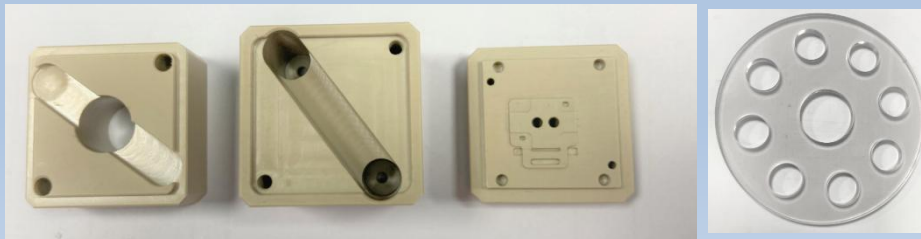

Resin Precision Parts





About YOSHIKAWA

Round needle precision mold parts





About YOSHIKAWA

Precision mold

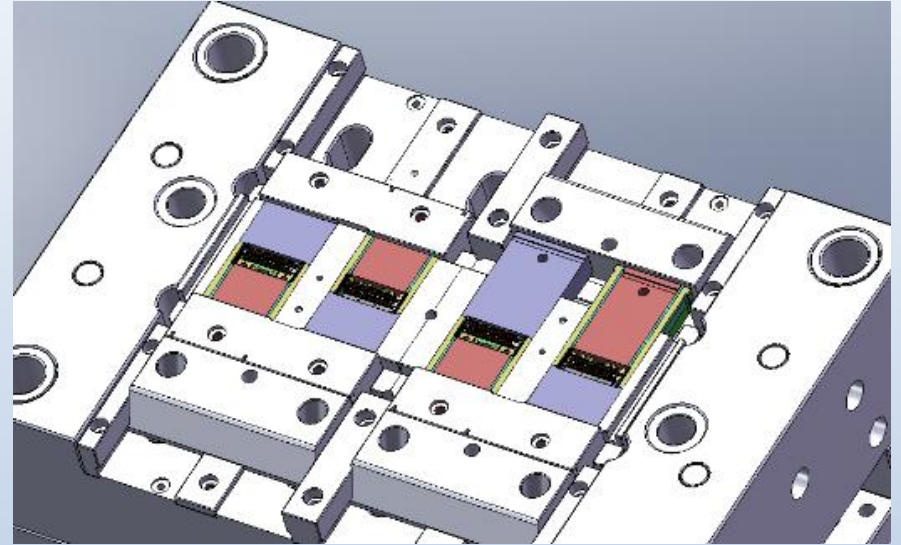
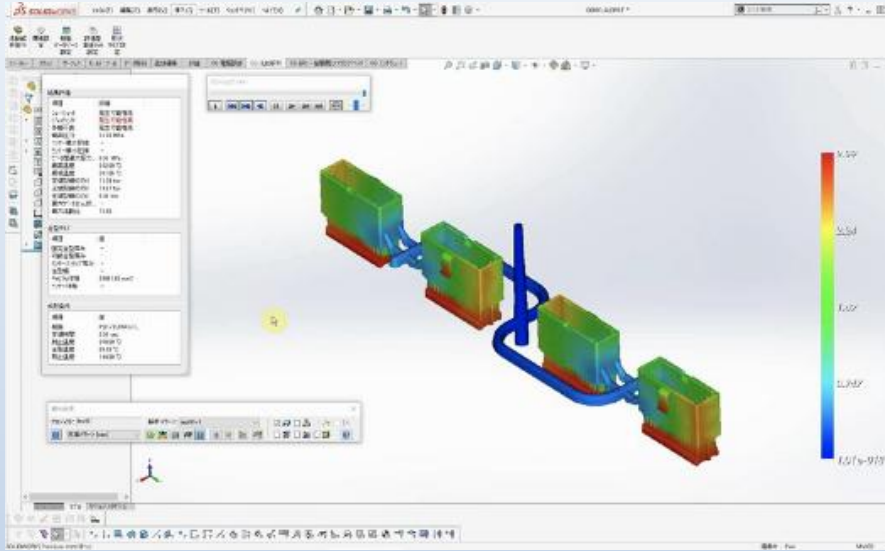



About YOSHIKAWA

Injection part



Automotive Connectors

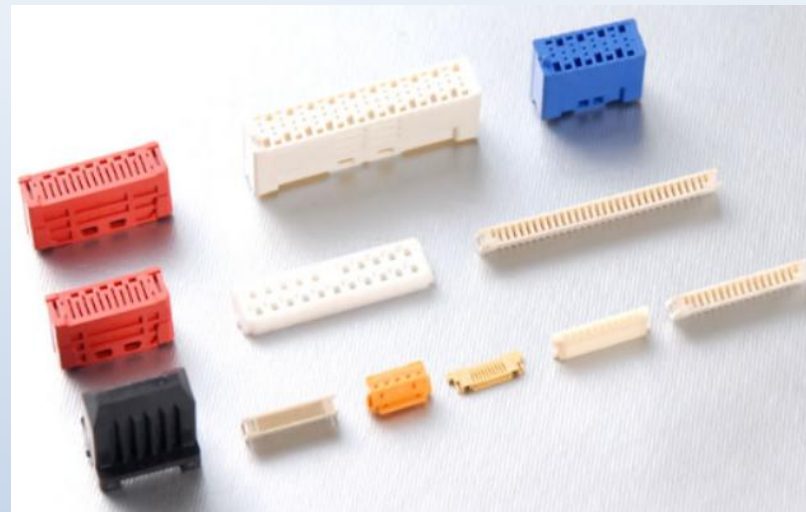

Connectors for Electronics



Precision Mechanical Components



Secondary forming



YOSHIKAWA



About YOSHIKAWA

Workshop & Equipment

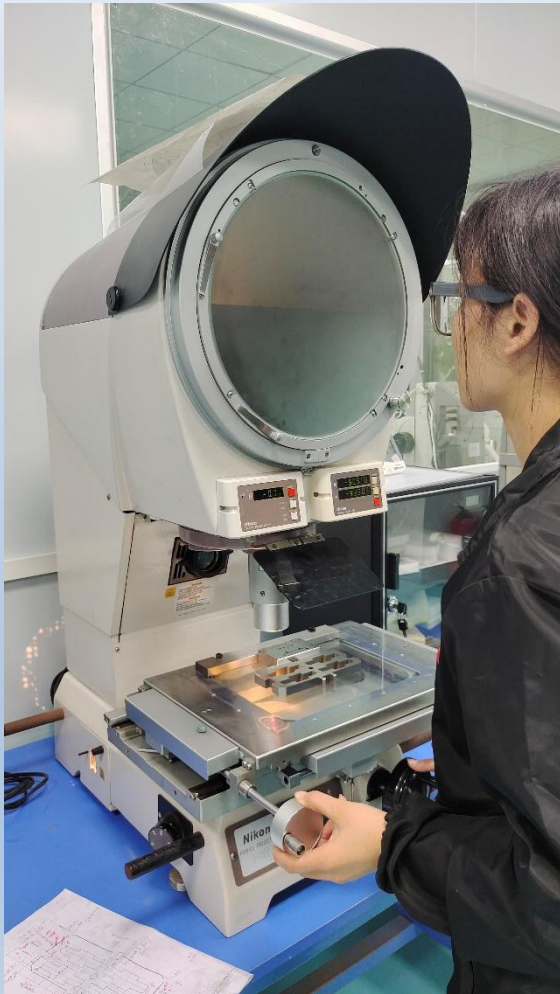

- Plant area : 1200m²
- Annual output of parts : 20000PCS
- Corresponding Accuracy :
 - grinding: 1μm
 - EDM: 2μm
 - Wire cut: 2μm





About YOSHIKAWA

Workshop & Equipment





About YOSHIKAWA

Workshop & Equipment





About YOSHIKAWA

Workshop & Equipment





About YOSHIKAWA

Workshop & Equipment

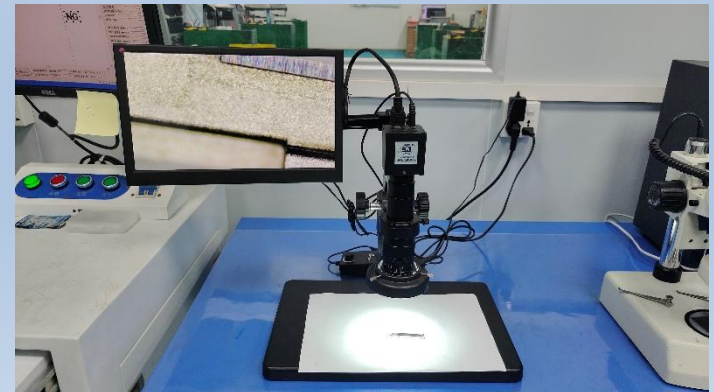



About YOSHIKAWA

Engineering

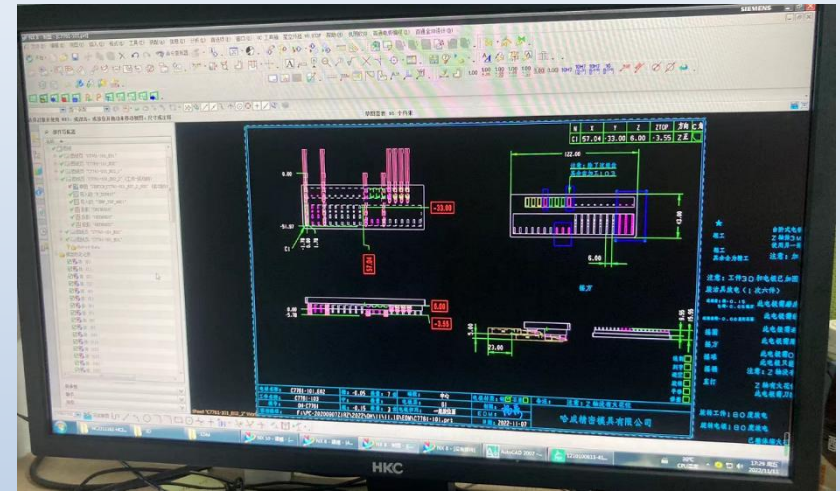
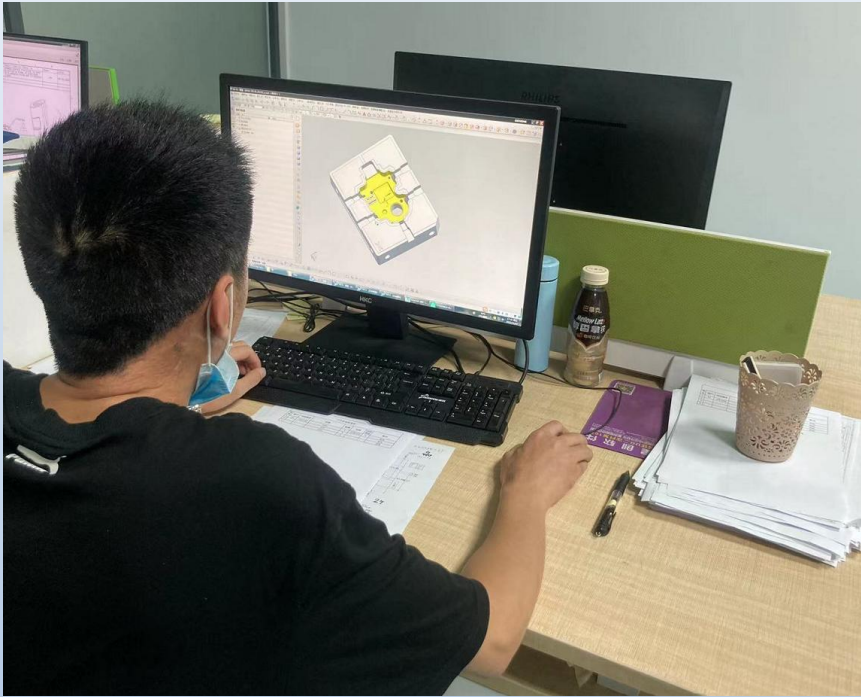

- We use state-of-the-art computer-aided software CAD/CAE/CAM, it guarantees efficiency and technical file conversion.
- (UG10.0 AutoCAD2021 SOLIDWORKS 2016
- Applicable file types STP,X_T,IGS.PRT,DXF,DWG



About YOSHIKAWA

Quality management systems



ISO9001:2015



ISO14001:2015



About YOSHIKAWA

Equipment List

Machine	Make	medel	Qty	Bed Size(mm)	Accuracy
Surface Grinding	qiangjiang	QJ618	4	150*350*225	± 0.002
Surface Grinding	shuguang	SGM350	5	150*350*225	± 0.002
CNC Surface Grinding	yudong	YD718	1	200*600*300	± 0.01
CNC Milling	beijingjingdiao	JDLVM400PZ	2	275*450*350	± 0.005
CNC Milling	beijingjingdiao	Carver400TEZ	1	275*450*350	± 0.005
CNC Milling	baofeng	BF650	2	635*520*460	± 0.010
Wire EDM	SEIBU	M50B	2	500*350*310	± 0.003
Wire EDM	SOLICK	SC540	2	330*540*400	± 0.01
Sink EDM	SODICK	AD32LS	3	250*350*200	± 0.005
Sink EDM	MITSUBISHI	EA8	1	200*250*200	± 0.005
Sink EDM	MAKINO	EDGE2i	2	250*350*250	± 0.005
Sink EDM	CREATOR	CR5	1	350*250*200	± 0.01



About YOSHIKAWA

Measuring Equipment

Instrument	Make	medel	Qty	Accuracy
PROFILE PROJECTOR	NIKON	Nikon V12B	2	± 0.003
TOOL MAKERS MICROSCOPE	NIKON	Nikon MM-400	3	± 0.003
HEIGHT GAUGE	NIKON	Nikon MFC 101A	12	± 0.001
HEIGHT GAUGE	Mitutoyo	LH-600E	1	± 0.003
SURFACE TEXTURE MEASURING EQUIPEMENT	Mitutoyo	SJ-210	1	5%
COORDINATE MEASURING MACHINE	inspector	600*800*600	1	2.4+L/300 μ m
hardness MACHINE	洛克	HR-150A	1	± 1 度
angle measuring instrument	Mitutoyo		1	
BLACK GAUGE	Mitutoyo		5	± 0.001
PIN GAUGE	Mitutoyo		3	± 0.001



Contact Us

Contact

DONGGUAN HACHENG MOULD CO., LTD
YOSHIKAWA KOUGYOU(H.K)CO.,LIMITED

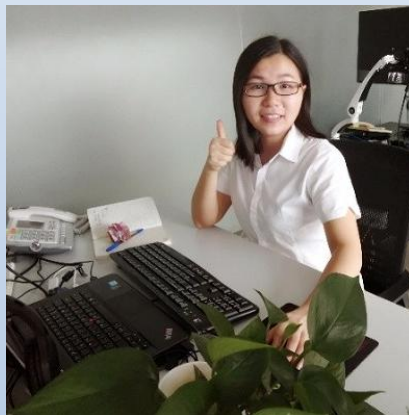

Anna Lyu
Marketing

Office: +86 769 8166 6379

Mobile: +86 18312522341 (Whatsapp, Wechat)

Email: anna.lyu@hacheng.net



YOSHIKAWA